

- Fully Integrated Custom Solution
- High Performance Microwave Switching
- 1.35 GHz Bandwidth
- Excellent RF & Repeatability Characteristics
- 50 Ω Characteristic Impedance
- Compact 4U Form Factor
- LXI Standard 1.4 Compliant
- IVI & Direct I/O Drivers
- Supplied With Custom Soft Front Panel
- 3 Year Warranty



Pickering Interfaces 60-891-024 is a customer defined test system that comprises various interconnected RF switches and associated RF components.

The microwave switching is provided by high quality SP6T (6 GHz), SPDT (18 GHz) and SPDT (High Speed, 0.5 GHz – 4 GHz) fitted with SMA connectors. These components offer low VSWR, very high isolation and low loss.

Additional RF components in the form of amplifier, coupler, attenuator, power detector and terminator are also provided to complete the integrated test solution

Controlling the System

The 60-891-024 is controlled through an LXI interface based on Ethernet 1000Base-T. This provides a quick and easy method of installing the 60-891-024 and a simple way of controlling the unit from a remote location through its API or built in custom soft front panel. The ability to control the unit at a distance allows the testing of systems without the need for a physical presence.

Other Microwave Switching Configurations

We are able to offer other microwave switching solutions, if you have a custom requirement for switching please contact your local Pickering Interfaces sales representative.

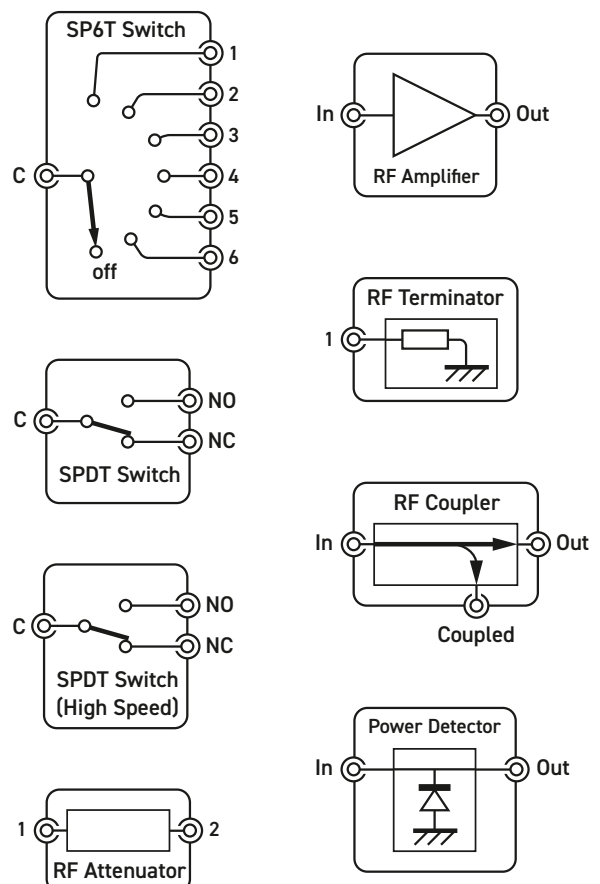

Components of the 60-891-024 Custom RF Drawer

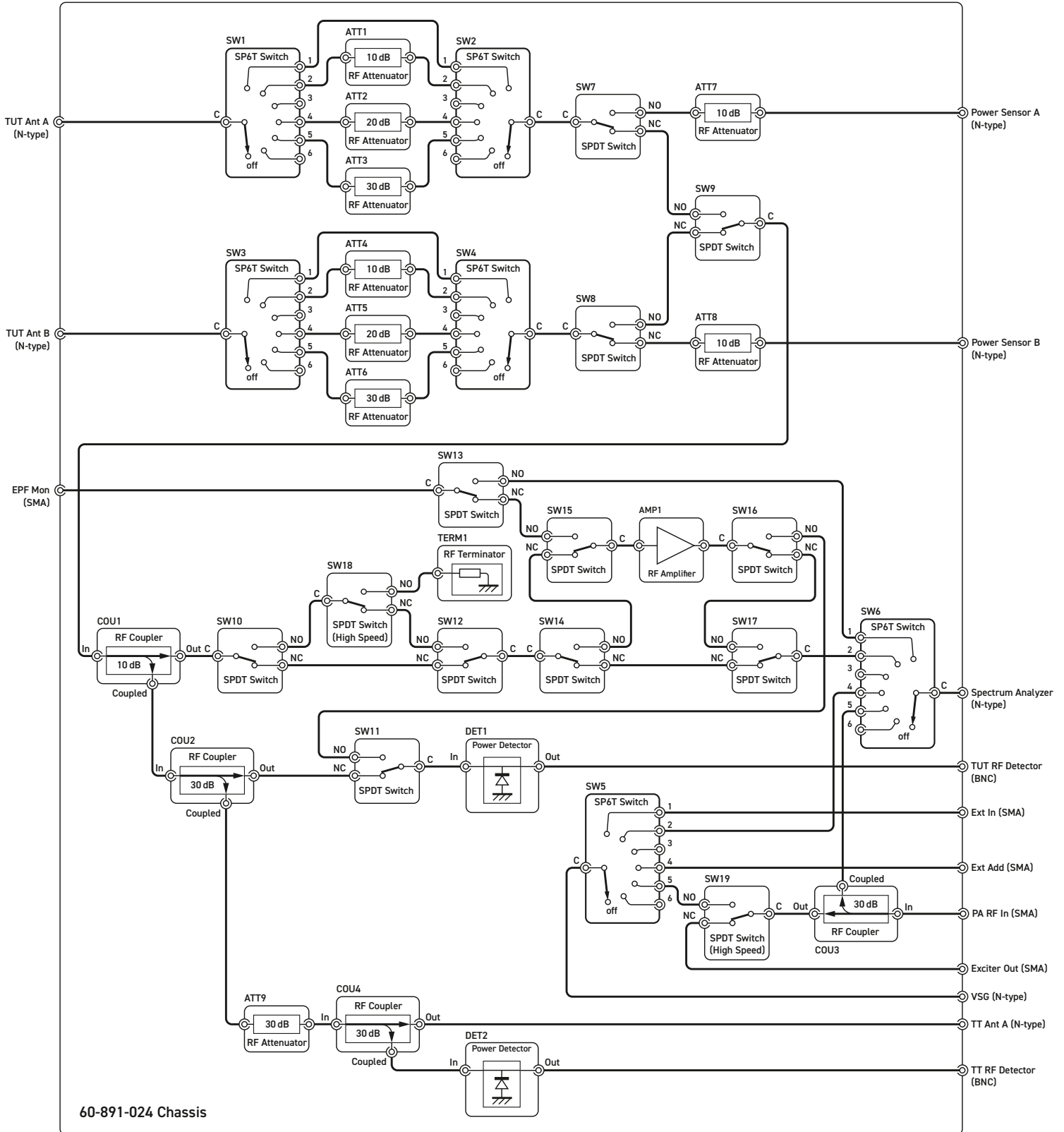

Schematic Diagram for the 60-891-024 Custom Microwave RF Drawer

Component Specifications

The specifications stated relate to the individual component parts and do not reflect that of complete signal paths through the test system.

SP6T Switch – 6 GHz (Component Ref. SW1-SW6)

Operating Frequency:	0 - 6 GHz
Characteristic Impedance:	50 Ω
Connector Type:	SMA
Insertion Loss:	<0.2 dB to 3 GHz <0.3 dB to 6 GHz
Isolation:	>80 dB to 3 GHz >70 dB to 6 GHz
VSWR:	<1.2:1 0 to 3 GHz <1.3:1 to 6 GHz
RF Average Carry Power at 25 °C:	250 W to 3 GHz 170 W to 6 GHz
Operate Time:	10 ms
Expected Life	>10 million operations

SPDT Switch – 18 GHz (Component Ref. SW7-SW17)

Operating Frequency:	0 - 18 GHz
Characteristic Impedance:	50 Ω
Connector Type:	SMA
Insertion Loss:	<0.15 dB to 3 GHz <0.2 dB to 8 GHz <0.25 dB to 12.4 GHz <0.35 dB to 18 GHz
Isolation:	>80 dB to 3 GHz >75 dB to 8 GHz >65 dB to 12.4 GHz >60 dB to 18 GHz
VSWR:	<1.1:1 to 3 GHz <1.2:1 to 8 GHz <1.2:1 to 12.4 GHz <1.3:1 to 18 GHz
RF Average Carry Power at 25 °C:	250 W to 3 GHz 150 W to 8 GHz 120 W to 12.4 GHz 110 W to 18 GHz
Operate Time:	10 ms
Expected Life:	>10 million operations

SPDT (High Speed) Switch – 4 GHz (Component Ref. SW18 & SW19)

Operating Frequency:	0.5 - 4 GHz
Characteristic Impedance:	50 Ω
Connector Type:	SMA
Insertion Loss:	<1.5 dB to 4 GHz
Isolation:	>70 dB to 4 GHz
VSWR:	<1.5:1 to 4 GHz
RF Power:	37 dBm
Operate Time:	500 ns

Attenuator 10 dB – 3 GHz (Component Ref. ATT1 & ATT2)

Supplier Details:	Pasternack, PE7388 series
Operating Frequency:	0 - 3 GHz
Characteristic Impedance:	50 Ω
Connectors:	N-Type
Attenuation:	10 dB
Average Power:	50 W
VSWR:	<1.15:1 to 3 GHz
Maximum Deviation:	+/- 0.3 dB

Attenuator 10 dB – 2 GHz (Component Ref. ATT7 & ATT8)

Supplier Details:	Radiall, R412 series
Operating Frequency:	0 - 2 GHz
Characteristic Impedance:	50 Ω
Connectors:	N-Type
Attenuation:	10 dB
Average Power:	2 W
VSWR:	<1.15:1 to 2 GHz
Maximum Deviation:	+/- 0.35 dB

Attenuator 20 dB – 3 GHz (Component Ref. ATT3 & ATT4)

Supplier Details:	Pasternack, PE7388 series
Operating Frequency:	0 - 3 GHz
Characteristic Impedance:	50 Ω
Connectors:	N-Type
Attenuation:	20 dB
Average Power:	50 W
VSWR:	<1.15:1 to 3 GHz
Maximum Deviation:	+/- 0.3 dB

Attenuator 30 dB – 4 GHz (Component Ref. ATT9)

Supplier Details:	Pasternack, PE7393 series
Operating Frequency:	0 - 4 GHz
Characteristic Impedance:	50 Ω
Connectors:	SMA
Attenuation:	30 dB
Average Power:	25 W
VSWR:	<1.25:1 to 4 GHz
Maximum Deviation:	+/- 0.6 dB

Attenuator 30 dB – 3 GHz (Component Ref. ATT5 & ATT6)

Supplier Details:	Pasternack, PE7388 series
Operating Frequency:	0 - 3 GHz
Characteristic Impedance:	50 Ω
Connectors:	N-Type
Attenuation:	30 dB
Average Power:	50 W
VSWR:	<1.15:1 to 3 GHz
Maximum Deviation:	+/- 0.4 dB

Coupler 10 dB – 3.7 GHz (Component Ref. COU1)

Supplier Details:	Mini-Circuits, ZGDC series
Operating Frequency:	0.38 – 3.7 GHz
Connectors:	N-Type
Coupling (typical):	11.4 dB to 0.6 GHz 10.0 dB to 3.7 GHz
Coupling Flatness:	<1.25 dB to 0.6 GHz <0.5 dB to 3.7 GHz
Average Power at 25 °C:	250 W to 2.7 GHz 150 W to 3.7 GHz
VSWR (typical):	<1.02:1 to 0.6 GHz <1.05:1 to 2.7 GHz <1.08:1 to 3.7 GHz
Mainline Loss:	0.2 dB to 0.6 GHz 0.3 dB to 2.7 GHz 0.35 dB to 3.7 GHz
Directivity (typical):	32 dB to 0.6 GHz 29 dB to 2.7 GHz 25 dB to 3.7 GHz

Coupler 30 dB – 3.7 GHz (Component Ref. COU2-COU4)

Supplier Details:	Mini-Circuits, ZGDC series
Operating Frequency:	0.38 – 3.7 GHz
Connectors:	N-Type
Coupling (typical):	31.5 dB to 0.6 GHz 30.0 dB to 2.7 GHz 30.7 dB to 3.7 GHz
Coupling Flatness:	<2.0 dB to 0.6 GHz <0.75 dB to 2.7 GHz <0.9 dB to 3.7 GHz
Average Power at 25 °C:	250 W to 2.7 GHz 150 W to 3.7 GHz
VSWR (typical):	<1.07:1 to 3.7 GHz
Mainline Loss:	0.2 dB to 0.6 GHz 0.3 dB to 2.7 GHz 0.3 5dB to 3.7 GHz
Directivity (typical):	30 dB to 0.6 GHz 27 dB to 2.7 GHz 24 dB to 3.7 GHz

Power Detector – 12.4 GHz (Component Ref. DET1-DET2)

Supplier Details:	Keysight, 423B
Operating Frequency:	0.01 – 12.4 GHz
Characteristic Impedance:	50 Ω
Connectors:	N-Type Input, BNC Output
VSWR:	<1.15:1 to 4 GHz <1.3:1 to 12.4 GHz
Broadband Flatness (typical):	0.01dB to 12.4 GHz
Average Power at 25 °C:	250 mW

Amplifier (Component Ref. AMP1)

Supplier Details:	Mini-Circuits, ZRL series
Operating Frequency:	7 - 3.5 GHz
Connectors:	SMA
Gain (typical):	26 dB to 1.6 GHz 22 dB to 2.6 GHz 17 dB to 3.5 GHz
Gain Flatness:	<3.2 dB to 1.6 GHz <3.8 dB to 2.6 GHz <4.0 dB to 3.5 GHz
Noise Figure:	<3.5 dB to 1.6 GHz <3.2 dB to 2.6 GHz <4.2 dB to 3.5 GHz
Output power at 1 dB gain compression (typical):	24 dBm
VSWR Input (typical):	1.4:1 to 2.6 GHz 1.5:1 to 3.5 GHz
VSWR Output (typical):	1.3:1 to 2.6 GHz 1.5:1 to 3.5 GHz

Terminator (Component Ref. TERM1)

Supplier Details:	Radiall, R404 series
Operating Frequency:	0 – 18 GHz
Characteristic Impedance:	50 Ω
Connectors:	SMA
VSWR:	1.1:1 to 8GHz 1.15:1 to 12.4GHz 1.2:1 to 18GHz
Average Power at 25 °C:	2 W

System Specifications

RF Specifications:	A test report detailing the insertion loss through all signal paths will be provided with the test system.
Mechanical Characteristics:	4U high, full 19" rack width, 500 mm deep. Supplied with front panel ears to enable rack mounting on a shelf or other rear support mechanism.
RF Connectors:	N-type, SMA & BNC (see Schematic Diagram for connector allocations)

Power Source

Universal AC mains supply, 90-120/200-240 V 50-60 Hz	
Power Inlet:	Male IEC connector
Power Rating:	100 VA maximum
Fuse Rating:	5 A, 250 V

LAN Interface

Compliant to LXI Standard 1.4, the 60-891-024 has a 1000Base-T Ethernet Interface via a standard RJ-45 connector mounted on the rear panel with an LCD display showing the unit's IP address.

LXI Status Indicators

Front panel mounted LEDs:

- Power
- Ready
- Error
- LAN
- Active

Cooling

Fan assisted cooling, front air intakes and rear exhaust.

Operating/Storage Conditions

Operating Temperature:	0 °C to +55 °C
Humidity:	Up to 90% non-condensing
Altitude:	5000 m
Storage/Transport Temperature:	-20 °C to +75 °C
Humidity:	Up to 90% non-condensing
Altitude:	15000 m

Safety & CE Compliance

All modules are fully CE compliant and meet applicable EU directives:

Low-voltage safety EN61010-1:2010,
EMC Immunity EN61326-1:2013,
Emissions EN55011:2009+A1:2010.

Product Order Codes

LXI Custom Microwave RF Drawer: 60-891-024

Product Customization

Pickering LXI units are designed and manufactured on our own flexible manufacturing lines, giving complete product control and enabling simple customization to meet very specific requirements.

Customization can include:

- Alternative relay types
- Mixture of relay types
- Alternative number of relays
- Different performance specifications

All customized products are given a unique part number, fully documented and may be ordered at any time in the future.

Please contact your local sales office to discuss.

Support Products

Mating Connectors & Cabling

For connection accessories for the 60-891-024 module please refer to the [90-011D](#) RF Cable Assemblies data sheet where a complete list and documentation can be found for accessories, or refer to our website.

Further LXI RF Switching Solutions from Pickering Interfaces



60-891-001 LXI 36:1 Microwave Multiplexer. Available With SMA Connectors (18 GHz) or BNC Connectors (4 GHz).



60-750/751 LXI Microwave Matrix. Bandwidth up to 20 GHz and is available in sizes from Single 3x3 up to Dual 4x4 with Loop-Thru and termination options.



60-721A LXI 72-Channel High Performance Video Multiplexer with a 1GHz bandwidth.



60-801/802 LXI Microwave Multiplexer, up to 40 GHz bandwidth and support for up to 16 banks of 6 or 4 way multiplexers.



60-800/803 LXI Microwave Multiplexer. Unterminated versions to 67 GHz with up to 16 banks. Terminated versions to 50 GHz with up to 14 banks. 6 or 4 way multiplexers supported.

Connectivity Solutions

We provide a full range of supporting cable and connector solutions for all our switching products—20 connector families with 1200+ products. We offer everything from simple mating connectors to complex cables assemblies and terminal blocks. All assemblies are manufactured by Pickering and are guaranteed to mechanically and electrically mate to our modules. These accessories are detailed in Connector Accessories data sheets, where a complete list and documentation can be found for each accessory.

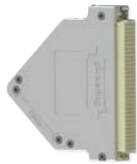

Connectors & Backshells



Multi-way Cable Assemblies

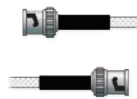

RF Cable Assemblies



Breakouts



Connector Blocks

We also offer customized cabling and have a free online **Cable Design Tool** that can be used to create custom cable solutions for many applications.

- Fully supported on modern browsers and tablet operating systems.
- Built-in tutorials and videos allow you to get quickly up to speed.
- Store cable assemblies in the Cloud and develop over time.
- Each cable design has a downloadable PDF documentation file detailing all specifications

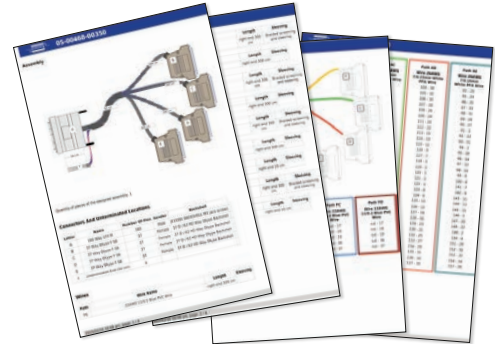

Start designing your custom cabling, go to pickeringtest.com/cdt

Mass Interconnect

We recommend the use of a mass interconnect solution when an Interchangeable Test Adapter (ITA) is required for PXI/LXI based test systems. Our modules are fully supported by Virginia Panel and MacPanel.

Pickering Reed Relays

We are the only switch provider with in-house reed relay manufacturing capability via our Relay Division. These instrument grade reed relays feature **SoftCenter™** technology, ensuring long service life and repeatable contact performance.

To learn more go to pickeringrelay.com

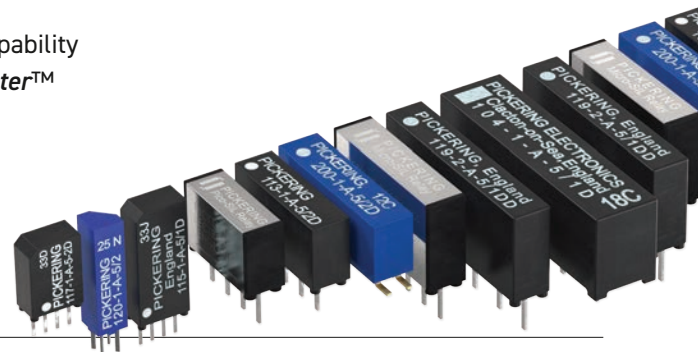

Programming

Pickering provide kernel, IVI and VISA (NI & Keysight) drivers which are compatible with all Microsoft supported versions of Windows and popular older versions.

For more information go to pickeringtest.com/os

The VISA driver support is provided for LabVIEW Real Time Operating Systems (Pharlap and Linux-RT). For other RTOS support contact Pickering. These drivers may be used with a variety of programming environments and applications including:

- **Pickering Interfaces Switch Path Manager**
- **National Instruments products** (LabVIEW, LabWindows/CVI, Switch Executive, MAX, TestStand, VeriStand, etc.)
- **Microsoft Visual Studio products** (Visual Basic, Visual C++)
- **Programming Languages** C, C++, C#, Python
- **Keysight VEE and OpenTAP**
- **Mathworks MATLAB, Simulink**
- **Marvin ATEasy**
- **MTQ Testsolutions Tecap Test & Measurement Suite**

Drivers for popular Linux distributions are available, other environments are also supported, please contact Pickering with specific enquiries. We provide Soft Front Panels (SFPs) for our products for familiarity and manual control, as well as comprehensive documentation and example programs to help you develop test routines with ease.

To learn more about software drivers and development environments go to pickeringtest.com/software

Signal Routing Software

Our signal routing software, Switch Path Manager, automatically selects and energizes switch paths through Pickering switching systems. Signal routing is performed by simply defining test system endpoints to be connected together, greatly accelerating Test System software development.

To learn more go to pickeringtest.com/spm

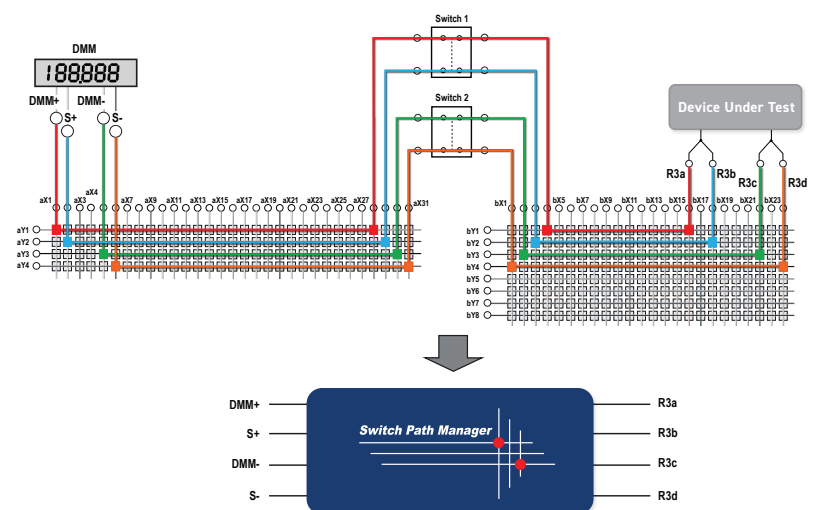

Diagnostic Relay Test Tools

eBIRST Switching System Test Tools are designed specifically for our PXI, PCI or LXI products, these tools simplify switching system fault-finding by quickly testing the system and graphically identifying the faulty relay.

To learn more go to pickeringtest.com/ebirst



Three Year Warranty & Guaranteed Long-Term Support

All standard products manufactured by Pickering Interfaces are warranted against defective materials and workmanship for three years from the date of delivery to the original purchaser. Extended warranty and service agreements are available with various levels for your requirements. Although we offer a 3-year warranty as standard, we also include guaranteed long-term support—with a history of supporting our products for typically 15-20 years.

To learn more go to pickeringtest.com/support

Available Product Resources

We have a library of resources including success stories, product and support videos, articles and white papers as well as application-specific brochures to assist you. We have also published reference books on switching technology and the PXI and LXI standards.

To view, download or request any of our product resources go to pickeringtest.com/resources

